

SMC Series Subminiature RF Connectors

ONLINE
CATALOG

Screw-on mating
Frequency range DC-10 GHz
Lightweight and economical



SLB and SMB connectors also shown for comparison



APPLIED ENGINEERING PRODUCTS

104 John W. Murphy Drive • P.O. Box 510 • New Haven, CT 06513

(203) 776-2813 • FAX (203) 776-8294

www.aepconnectors.com • e-mail: aepsales@aepconnectors.com

SMC Subminiature Connectors

Click on any line below to go directly to the appropriate page

Contents

Technical Information

Interfaces and specifications	2
Cable attachment methods	3

Cable Connectors

Straight plugs for flexible and semi-rigid cable	4
Right angle plugs for flexible and semi-rigid cable	4
Straight jacks for flexible and semi-rigid cable	5
Right angle jacks for flexible and semi-rigid cable	5
Straight bulkhead jacks for flexible and semi-rigid cable	6
Right angle bulkhead jacks for flexible and semi-rigid cable	6

Receptacles

Bulkhead receptacles	7
Straight P.C. board jacks	8
Straight bulkhead mounted P.C. board jacks	8
Straight P.C. board plugs	8
Right angle P.C. board jacks	9
Right angle bulkhead mounted P.C. board jacks	9
Right angle P.C. board plugs	9
Panel mounted jack receptacles	10
Stripline receptacles	11

Adapters

Straight adapters within series	12
Tee adapters within series	13

Resistive Terminations

Plug resistive terminations	14
Jack resistive terminations	14

Cable Assembly Instructions

Clamp type connectors for flexible cable	15
Crimp type connectors for flexible cable	16
Solder-clamp connectors for semi-rigid cable	17

Assembly Tooling	18
----------------------------	----

Mounting Dimensions	18
-------------------------------	----

Index by AEP Part Number	19
------------------------------------	----

About AEP	20
---------------------	----

Other AEP Product Lines	21
-----------------------------------	----



APPLIED ENGINEERING PRODUCTS

104 John W. Murphy Drive • P.O. Box 510 • New Haven, CT 06513

(203) 776-2813 • FAX (203) 776-8294

www.aepconnectors.com • e-mail: aepsales@aepconnectors.com

SMC Specifications

Specifications (MIL-PRF-39012 as applicable)

Materials:

Body components, male contacts: Brass per ASTM-B-16, alloy 360, 1/2 hard.

Female contacts: Beryllium copper per ASTM-B-196, Condition HT.

Insulators: Teflon TFE per ASTM-D-1710.

Finish:

Center contacts: Gold plated per current revision of MIL-PRF-39012*

Other metal parts: Gold or nickel plated to meet current MIL-PRF-39012 corrosion requirements.*

Electrical:

Impedance: 50Ω. **Frequency range:** DC–10 GHz. **Insulation Resistance:** 1,000 megohms minimum.

Voltage Rating: 250VRMS @ sea level (RG-178 cable); 335VRMS @ sea level (RG-316 cable).

Dielectric Withstanding Voltage: 750VRMS @ sea level (RG-178 cable); 1000VRMS @ sea level (RG-316 cable).

Contact Resistance:

Straight connectors: Initial: 6 milliohms maximum; after environmental test conditions: 8 milliohms maximum.

Right angle connectors: Initial: 12 milliohms maximum; after environmental test conditions: 16 milliohms maximum.

Corona level: 125V @70,000 ft. **RF highpot:** 400 VRMS @ 5 MHz.

RF leakage: -60 dB min @ 2–3 GHz. **Insertion loss:** .25 dB max (straight connectors), .50 dB max (right angle connectors) @ 1.5 GHz.

VSWR:	Cable	Straight connector	Right angle connector
	RG-178	1.25 + (.04 x F[GHz])	1.40 + (.06 x F[GHz])
	RG-316	1.20 + (.04 x F[GHz])	1.33 + (.04 x F[GHz])

Mechanical:

Mating torque: 35–50 inch-ounces. **Coupling nut pulloff resistance:** 35 pounds min.

Contact retention: 2 pounds min axial force. **Durability:** 500 mating cycles.

Environmental (MIL-STD-202):

Temperature range: -65° C to +165° C. **Corrosion:** Method 101, condition B, 5% salt solution.

Vibration (Method 204): Condition D.

Mechanical shock (Method 213): Condition C. **Thermal shock (Method 107):** Condition B.

*These specifications change periodically with updates to MIL-PRF-39012 requirements. Contact factory for latest specifications.

Interface Dimensions

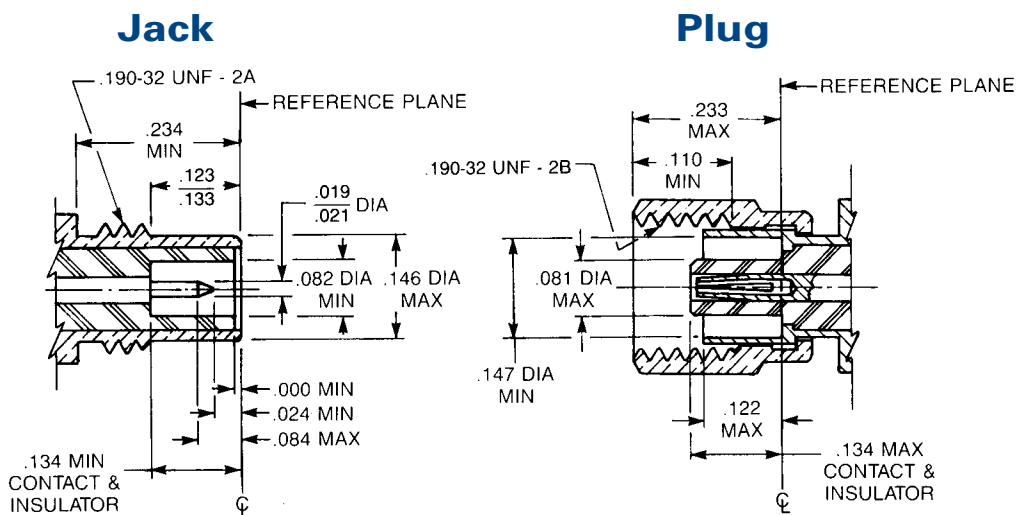

SMC Cable Attachment Methods

All SMC cable connectors in this catalog have captivated contacts which are soldered to the cable center conductor.

Both crimp and clamp types for flexible cable grip the cable braid with a force greater than the breaking strength of the braid.

Clamp Type For Flexible Cable

These connectors can be assembled without special tooling, and are field replaceable. They provide metal-to-metal clamping of the cable braid.

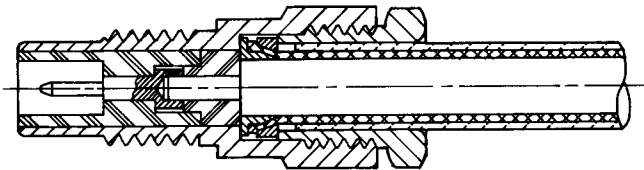

Crimp Type For Flexible Cable

Crimping the cable braid is the most reliable and repeatable method of cable assembly, and provides support for the cable during flexure. AEP crimp type connectors are assembled quickly and easily using readily-available commercial or MIL crimp tools.

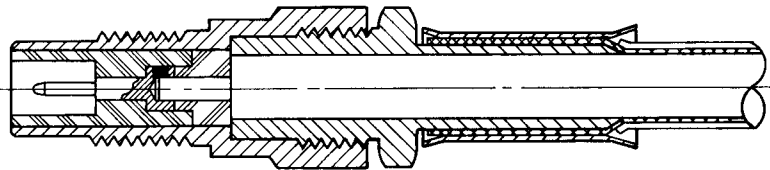

Solder-Clamp For Semi-Rigid Cable

This method allows retrimming of the cable dielectric, if necessary, during assembly. Connectors can be repositioned relative to the cable after assembly by loosening the clamp nut. Solder-clamp connectors are field replaceable without special tools.

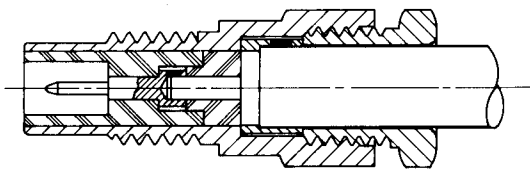

SMC Cable Plugs

Click on part number to go directly to cable assembly instructions

Straight Plugs

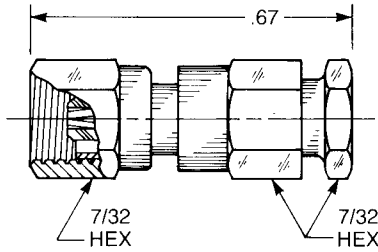

Straight Female Cable Plug

Clamp type for flexible cable:
1002-1551-0XX (Gold plated)
1002-7551-0XX (Nickel plated)

Solder-clamp for semi-rigid cable:
1002-1541-0XX (Gold plated)
1002-7541-0XX (Nickel plated)

QPL version available (M39012/73)

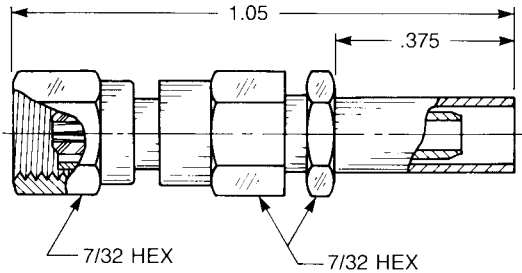

Straight Female Cable Plug

Crimp type for flexible cable:
1002-1571-0XX (Gold plated)
1002-7571-0XX (Nickel plated)

QPL version available (M39012/73)

Right Angle Plugs

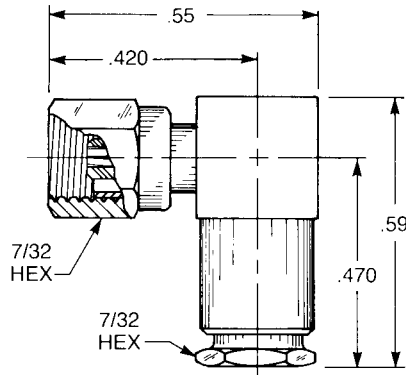

Right Angle Female Cable Plug

Clamp type for flexible cable:
1005-1551-0XX (Gold plated)
1005-7551-0XX (Nickel plated)

Solder-clamp for semi-rigid cable:
1005-1541-0XX (Gold plated)
1005-7541-0XX (Nickel plated)

QPL version available (M39012/75)

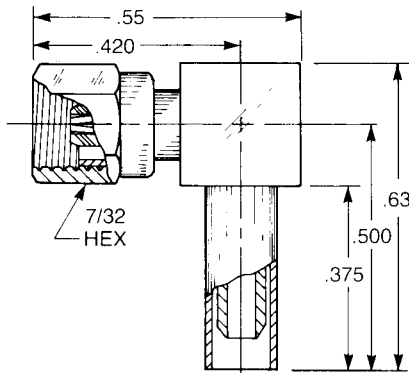

Right Angle Female Cable Plug

Crimp type for flexible cable:
1105-1521-0XX (Gold plated)
1105-7521-0XX (Nickel plated)

QPL version available (M39012/75)

Substitute the appropriate cable group number for "XX" when ordering:

GROUP	CABLE TYPES	GROUP	CABLE TYPES	GROUP	CABLE TYPES
02	RG178, RG196, M17/93, M17/169	05	RG178DS, RG196DS	10	.085" semi-rigid, RG405, M17/133
03	RG174, RG179, RG316, M17/113, M17/119, M17/172, M17/189	09	.141" semi-rigid, RG 402M17/130	19	RG174DS, RG316DS, M17/151, M17/152, Times RD-316



APPLIED ENGINEERING PRODUCTS

(203) 776-2813 • FAX (203) 776-8294

www.aepconnectors.com • aepsales@aepconnectors.com

SMC Cable Jacks

Click on part number to go directly to cable assembly instructions

Straight Jacks

Straight Male Cable Jack

Clamp type for flexible cable: Solder-clamp for semi-rigid cable:
 1001-1551-0XX (Gold plated) 1001-1541-0XX (Gold plated)
 1001-7551-0XX (Nickel plated) 1001-7541-0XX (Nickel plated)

QPL version
 available (M39012/74)

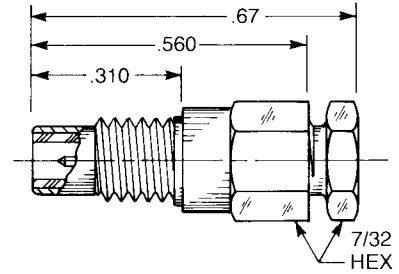

Straight Male Cable Jack

Crimp type for flexible cable:
 1001-1571-0XX (Gold plated)
 1001-7571-0XX (Nickel plated)

QPL version available (M39012/74)

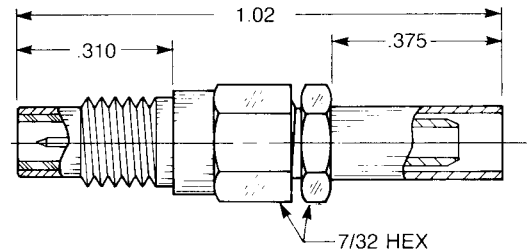

Right Angle Jacks

Right Angle Male Cable Jack

Clamp type for flexible cable:
 1041-1551-0XX (Gold plated)
 1041-7551-0XX (Nickel plated)

Solder-clamp for semi-rigid cable:
 1041-1541-0XX (Gold plated)
 1041-7541-0XX (Nickel plated)

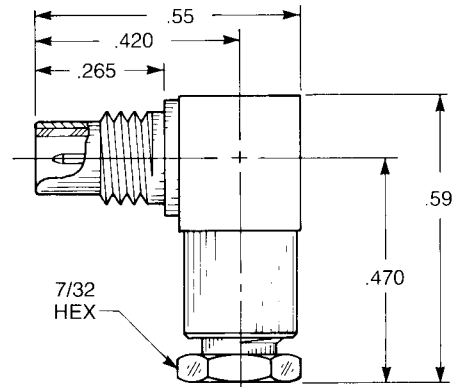

Right Angle Male Cable Jack

Crimp type for flexible cable:
 1141-1521-0XX (Gold plated)
 1141-7521-0XX (Nickel plated)

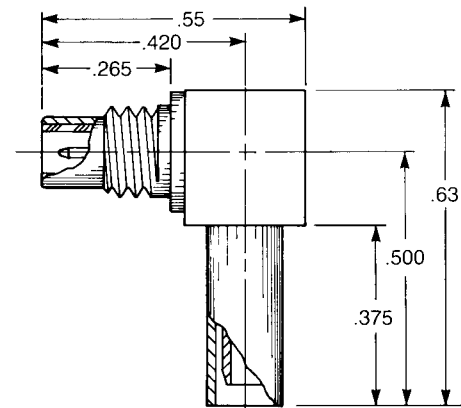

Substitute the appropriate cable group number for "XX" when ordering:

GROUP	CABLE TYPES	GROUP	CABLE TYPES	GROUP	CABLE TYPES
02	RG178, RG196, M17/93, M17/169	05	RG178DS, RG196DS	10	.085" semi-rigid, RG405, M17/133
03	RG174, RG179, RG316, M17/113, M17/119, M17/172, M17/189	09	.141" semi-rigid, RG 402M17/130	19	RG174DS, RG316DS, M17/151, M17/152, Times RD-316

SMC Bulkhead Mounted Cable Jacks

Click on part number to go directly to cable assembly instructions

Straight Jacks

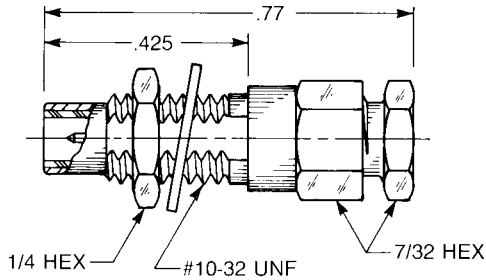

Straight Male Bulkhead Cable Jack

Clamp type for flexible cable: Solder-clamp for semi-rigid cable:
 1003-1551-0XX (Gold plated) 1003-1541-0XX (Gold plated)
 1003-7551-0XX (Nickel plated) 1003-7541-0XX (Nickel plated)

QPL version available (M39012/76)

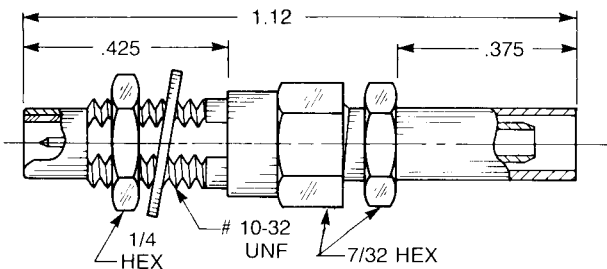

Straight Male Bulkhead Cable Jack

Crimp type for flexible cable:
 1003-1571-0XX (Gold plated)
 1003-7571-0XX (Nickel plated)

QPL version available (M39012/76)

Right Angle Jacks

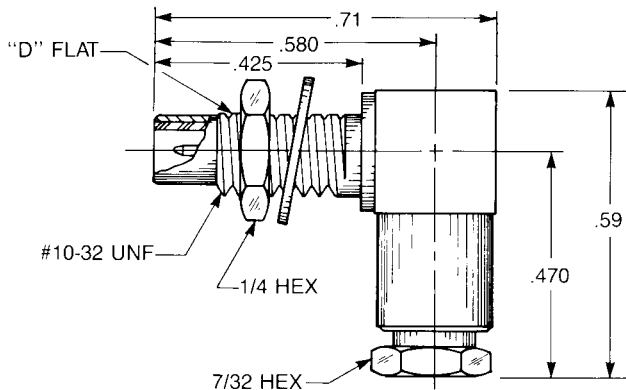

Bulkhead Mounted Right Angle Male Cable Jack

Clamp type for flexible cable:
 1006-1551-0XX (Gold plated)
 1006-7551-0XX (Nickel plated)

Solder-clamp for semi-rigid cable:
 1006-1541-0XX (Gold plated)
 1006-7541-0XX (Nickel plated)

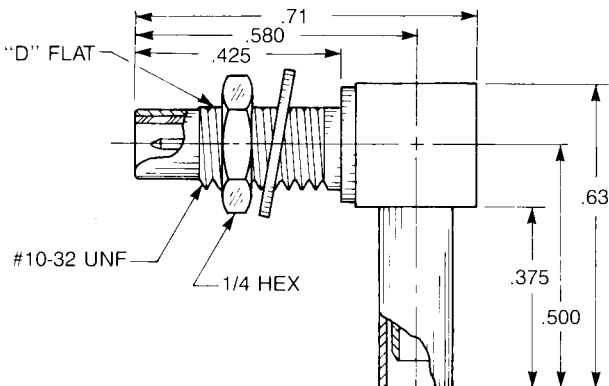

Bulkhead Mounted Right Angle Male Cable Jack

Crimp type for flexible cable:
 1106-1521-0XX (Gold plated)
 1106-7521-0XX (Nickel plated)

Substitute the appropriate cable group number for "XX" when ordering:

GROUP	CABLE TYPES	GROUP	CABLE TYPES	GROUP	CABLE TYPES
02	RG178, RG196, M17/93, M17/169	05	RG178DS, RG196DS	10	.085" semi-rigid, RG405, M17/133
03	RG174, RG179, RG316, M17/113, M17/119, M17/172, M17/189	09	.141" semi-rigid, RG 402M17/130	19	RG174DS, RG316DS, M17/151, M17/152, Times RD-316



APPLIED ENGINEERING PRODUCTS

(203) 776-2813 • FAX (203) 776-8294

www.aepconnectors.com • aepsales@aepconnectors.com

SMC Bulkhead Receptacles

Straight Jacks

Straight Male Bulkhead Jack Receptacle

- Solder pot contact
- Rear mount

1004-1511-000 (Gold plated)

1004-7511-000 (Nickel plated)

QPL version available (M39012/77)

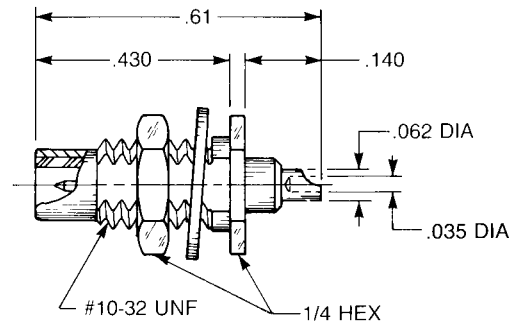

Straight Male Bulkhead Jack Receptacle

- Solder pot contact
- Front mount

1019-1511-000 (Gold plated)

1019-7511-000 (Nickel plated)

QPL version available (M39012/77)

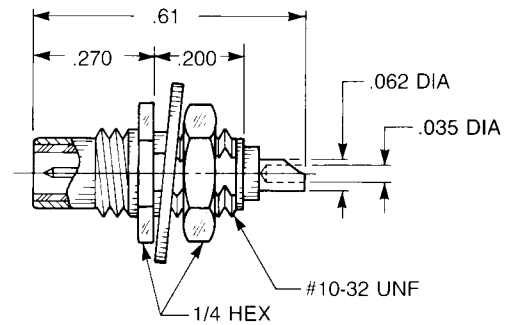

Right Angle Jack

Right Angle Male Bulkhead Jack Receptacle

- Solder pot contact
- Front mount

1012-1511-000 (Gold plated)

1012-7511-000 (Nickel plated)

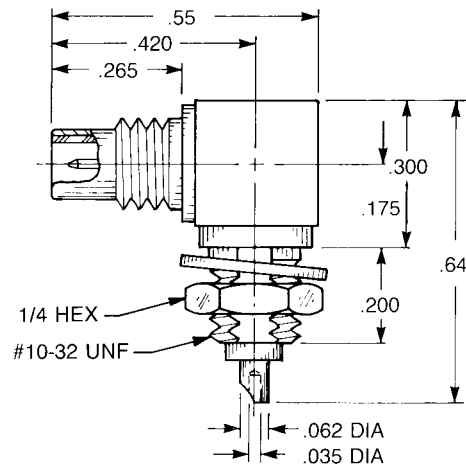

Straight Plug

Straight Female Bulkhead Plug Receptacle

- Solder pot contact
- Front mount

1017-1511-000 (Gold plated)

1017-7511-000 (Nickel plated)

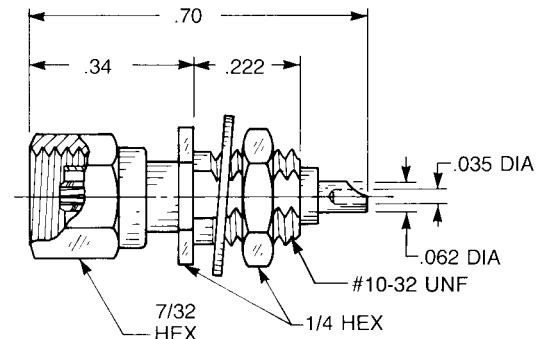

(All fit .093" max panel thickness)

SMC P.C. Board Receptacles

Straight Jacks

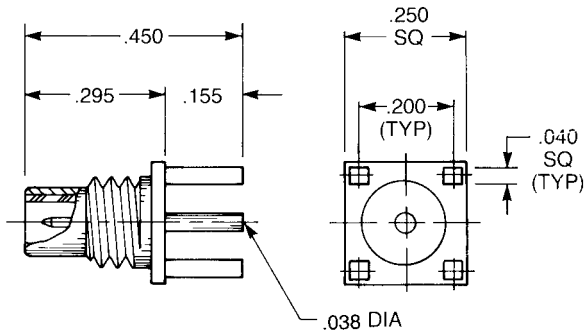

Straight Male Jack Receptacle

1009-1511-000 (Gold plated)
1009-7511-000 (Nickel plated)

Bulkhead Mounted Straight Male Jack P.C. Board Receptacle

1109-1511-000 (Gold plated)
1109-7511-000 (Nickel plated)

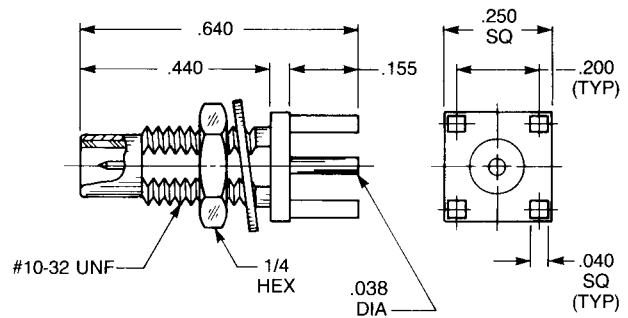

Straight Plug

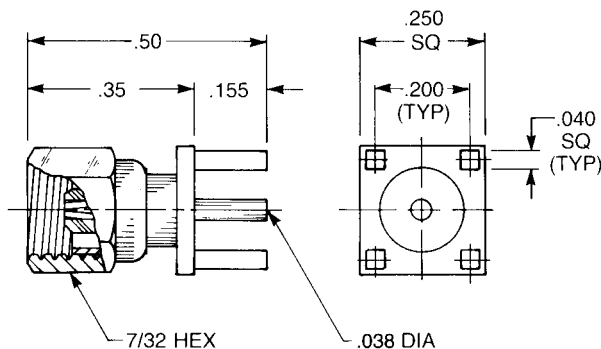

Straight Female Plug Receptacle

1025-1511-000 (Gold plated)
1025-7511-000 (Nickel plated)



SMC P.C. Board Receptacles

Right Angle Jacks

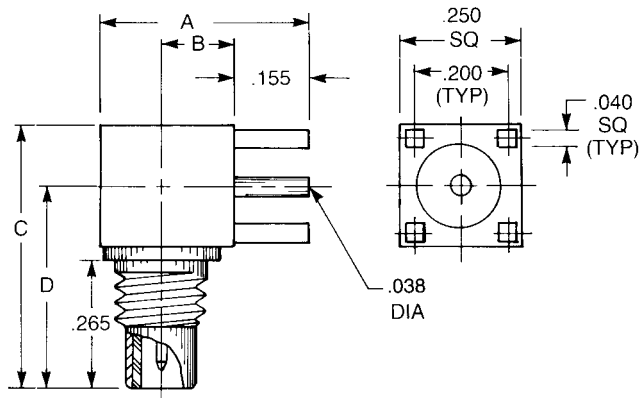

Right Angle Male Jack Receptacle

A	B	C	D
.43	.15	.55	.42
1010-1511-000		(Gold plated)	
1010-7511-000		(Nickel plated)	

A	B	C	D
.50	.215	.55	.42
1010-1511-001		(Gold plated)	
1010-7511-001		(Nickel plated)	

Bulkhead Mounted Right Angle Male Jack P.C. Board Receptacle

1110-1511-000 (Gold plated)
1110-7511-000 (Nickel plated)

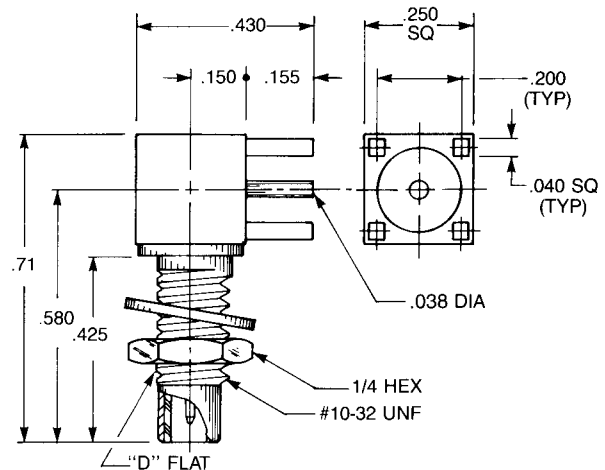

Right Angle Plug

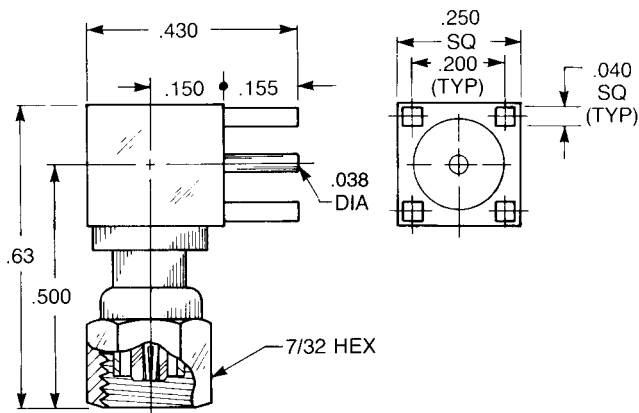

Right Angle Female Plug Receptacle

1042-1511-000 (Gold plated)
1042-7511-000 (Nickel plated)

SMC Panel Receptacles

Straight Jack

Straight Male Panel Receptacle

A sq.	B	C dia.
.500	.340	.102
1486-1511-000		(Gold plated)
1486-7511-000		(Nickel plated)

A sq.	B	C dia.
.375	.232	.093
1484-1511-000		(Gold plated)
1484-7511-000		(Nickel plated)

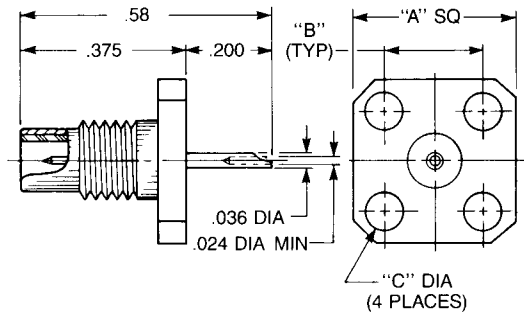

Right Angle Jack

Right Angle Male Panel Receptacle

A sq.	B	C dia.
.500	.340	.102
1490-1511-000		(Gold plated)
1490-7511-000		(Nickel plated)

A sq.	B	C dia.
.375	.232	.093
1488-1511-000		(Gold plated)
1488-7511-000		(Nickel plated)

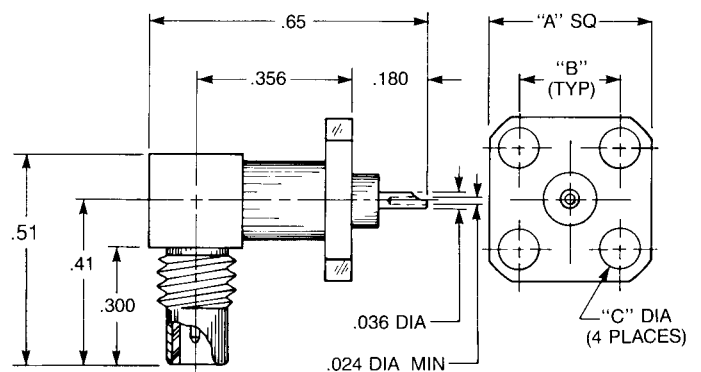

SMC Stripline Receptacles

Straight Jack

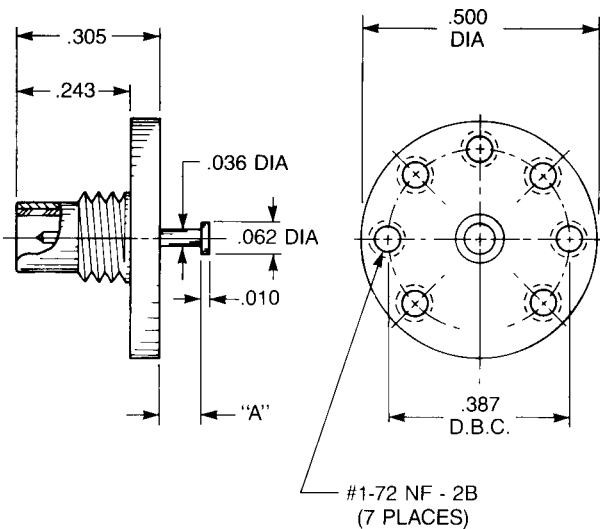

Straight Male Top Launch Jack

- Non-captive contact

Dim. A	Part number	
.031	1029-1211-001	(Gold plated)
	1029-7211-001	(Nickel plated)
.063	1029-1211-002	(Gold plated)
	1029-7211-002	(Nickel plated)
.125	1029-1211-003	(Gold plated)
	1029-7211-003	(Nickel plated)

Right Angle Jack

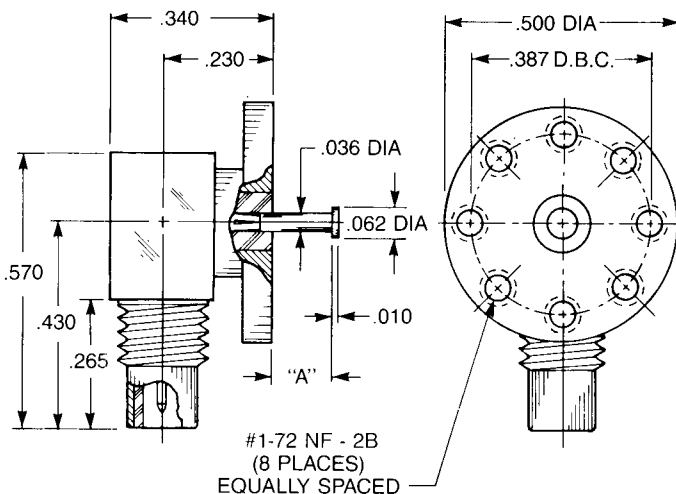

Right Angle Male Top Launch Jack

- Removable rear contact

Dim. A	Part number	
.031	1092-1511-001	(Gold plated)
	1092-7511-001	(Nickel plated)
.063	1092-1511-002	(Gold plated)
	1092-7511-002	(Nickel plated)
.125	1092-1511-003	(Gold plated)
	1092-7511-003	(Nickel plated)

SMC Adapters

Straight Adapters

Straight Male Jack To Jack Adapter

- Connects two plugs

5813-1501-000 (Gold plated)

5813-7501-000 (Nickel plated)

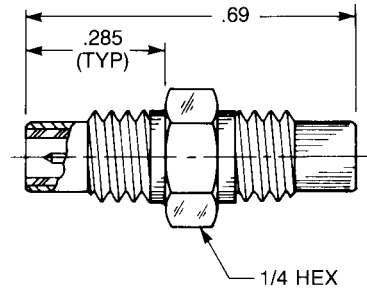

Bulkhead Mounted Straight Male Jack To Jack Adapter

- Connects two plugs
- For .093" max. panel

5822-1501-000 (Gold plated)

5822-7501-000 (Nickel plated)

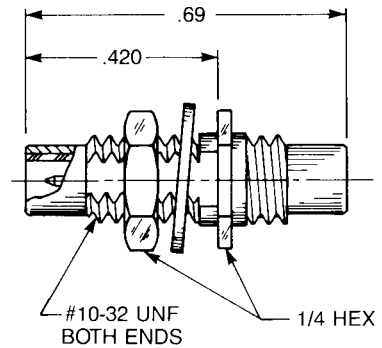

Straight Female Plug To Plug Adapter

- Connects two jacks

5816-1501-000 (Gold plated)

5816-7501-000 (Nickel plated)

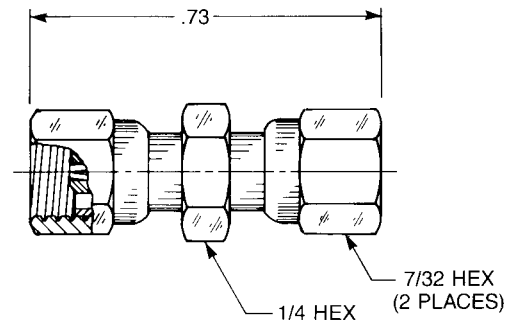

SMC Adapters

Tee Adapters

Tee Adapter (Unmatched Power Divider) Jack To Plug To Jack

- Connects two plugs and one jack

5815-1501-000 (Gold plated)

5815-7501-000 (Nickel plated)

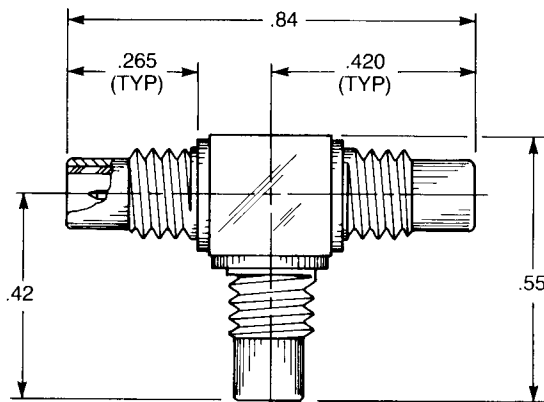
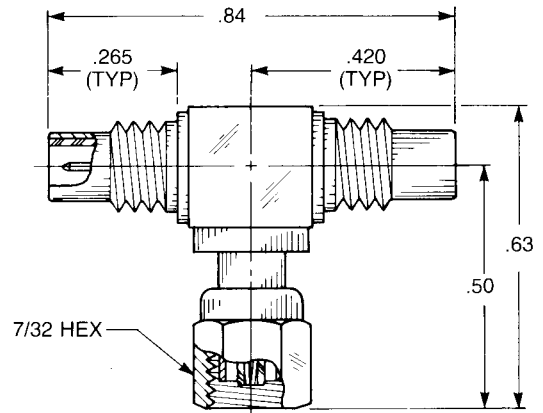

Tee Adapter (Unmatched Power Divider) Jack To Jack To Jack

- Connects three plugs

5807-1501-000 (Gold plated)

5807-7501-000 (Nickel plated)

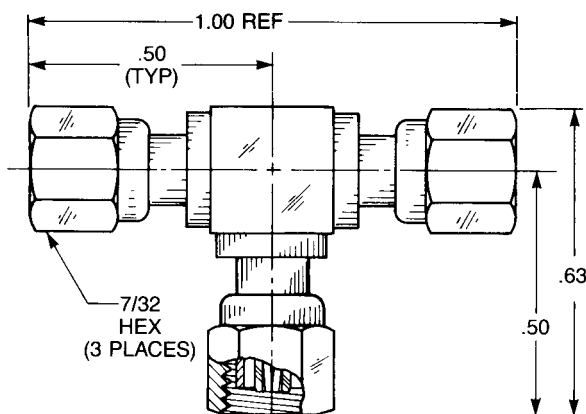

Tee Adapter (Unmatched Power Divider) Plug To Plug To Plug

- Connects three jacks

5808-1501-000 (Gold plated)

5808-7501-000 (Nickel plated)



SMC Terminations

Plug Termination

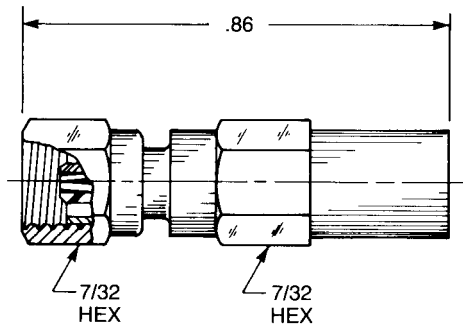

Female Plug Resistive Termination

(Dummy load)

Standard resistor:
51 ohm, 1/2 watt,
5% tolerance

1036-1511-051 (Gold plated)
1036-7511-051 (Nickel plated)

Available with other resistances

Jack Termination

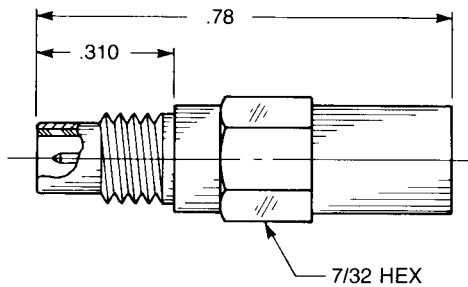

Male Jack Resistive Termination

(Dummy load)

Standard resistor:
51 ohm, 1/2 watt,
5% tolerance

1037-1511-051 (Gold plated)
1037-7511-051 (Nickel plated)

Available with other resistances



Cable Assembly Instructions

Clamp type connectors for flexible cable

Straight Connectors—Flexible Cable

Parts list

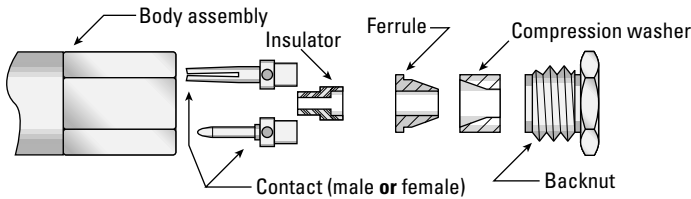

1

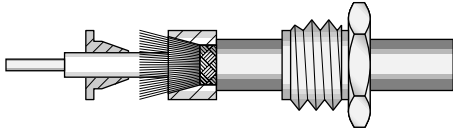

- Trim cable per trim code below; tin end of center conductor.
- Slide backnut onto cable. Slide compression washer onto cable in the orientation shown until it stops against cable jacket.
- Flare cable braid by rotating dielectric and slide ferrule under braid.

2

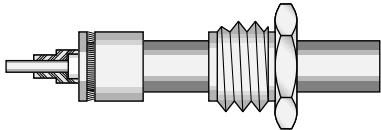

- Press ferrule against compression washer.
- Trim excess braid flush with outer diameter of compression washer and ferrule.
- Assemble insulator over cable center conductor and dielectric.

3

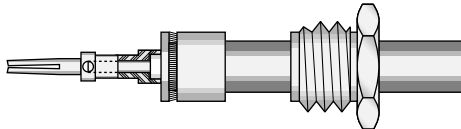

- Assemble contact onto cable center conductor.
- Solder contact to center conductor by heating rear of contact (do not feed additional solder through inspection hole in contact).

4

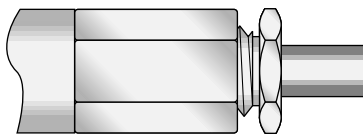

- Insert cable assembly into body assembly. Tighten to 90–100 inch-ounces torque. (Hold cable/hardware assembly stationary and rotate body when tightening.)

Cable Trim Dimensions

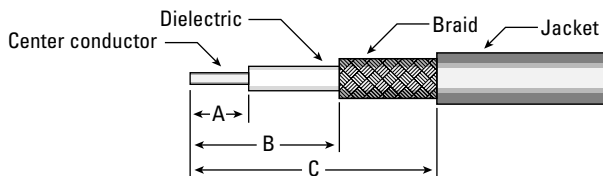

CONNECTOR TYPE	A	B	C
STRAIGHT CONNECTORS	.080	.120	.240
RIGHT ANGLE CONNECTORS	.080	.180	.300

Right Angle Connectors—Flexible Cable

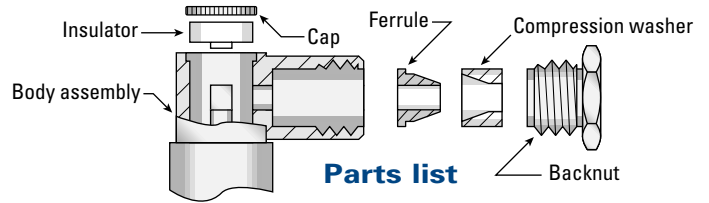

1

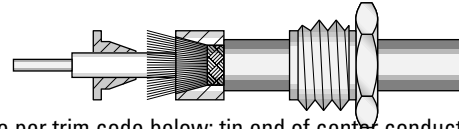

- Trim cable per trim code below; tin end of center conductor.
- Slide backnut onto cable. Slide compression washer onto cable in the orientation shown until it stops against cable jacket.
- Flare cable braid by rotating dielectric and slide ferrule under braid.

2

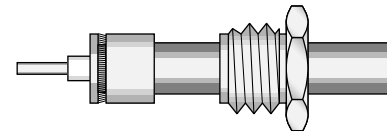

- Press ferrule against compression washer.
- Trim excess braid flush with outer diameter of compression washer and ferrule.
- Assemble insulator over cable center conductor and dielectric.

3

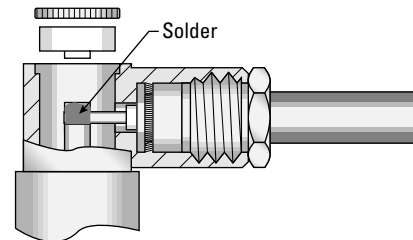

- Insert cable assembly into body assembly. Tighten to 90–100 inch-ounces torque. (Hold cable/hardware assembly stationary and rotate body when tightening.)
- Solder center conductor into notch in rear of contact with .025–.032" diameter chisel-tip soldering iron.
- Solder should cover center conductor, but not extend over top of notch in contact, or exceed contact diameter.

4

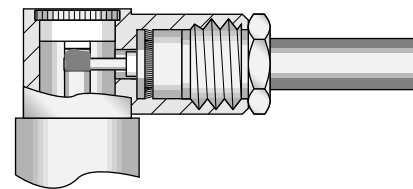

- Place insulator in body cavity, and press cap into place. Properly assembled cap will be slightly below end of body assembly.

Cable Assembly Instructions

Crimp type connectors for flexible cable

Straight Connectors—Flexible Cable

Parts list

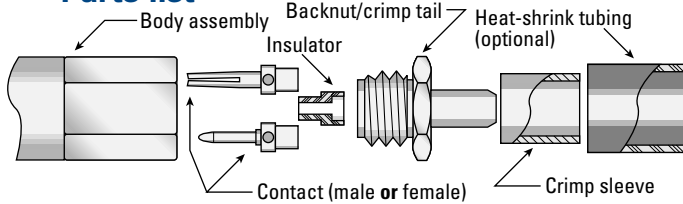

1

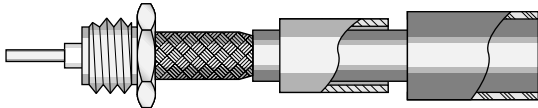

- Trim cable per trim code below; tin end of center conductor.
- Slide heat-shrink tubing and crimp sleeve over cable.
- Flare cable braid by rotating dielectric and slide cable into crimp tail.

2

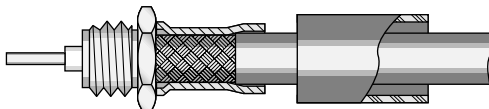

- Position cable so braid touches rear of back nut.
- Slide crimp sleeve forward to touch rear of back nut.
- Crimp braid with appropriate die size from chart below.

3

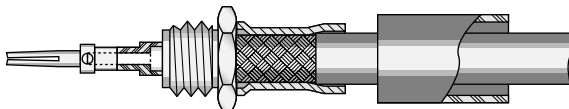

- Assemble insulator and contact onto cable dielectric and center conductor.
- Solder contact to center conductor by heating rear of contact (do not feed additional solder through inspection hole in contact).

4

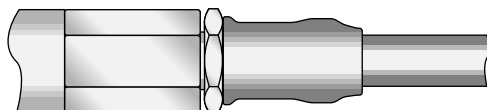

- Insert cable assembly into body assembly. Tighten to 90–100 inch-ounces torque. (Hold cable/hardware assembly stationary and rotate body when tightening.)
- Slide shrink tubing over crimp sleeve and shrink to fit.

Cable Trim Dimensions

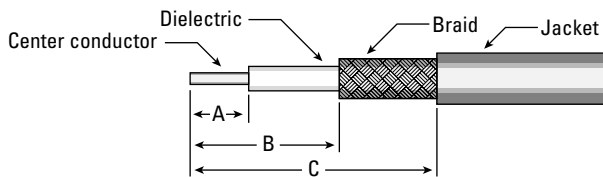

CONNECTOR TYPE	A	B	C
STRAIGHT CONNECTORS	.100	.430	.700
RIGHT ANGLE CONNECTORS	.070	.200	.450

Right Angle Connectors—Flexible Cable

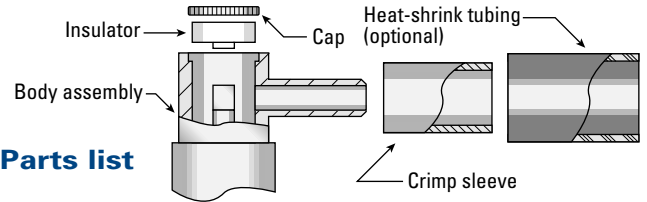

1

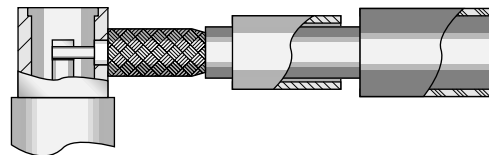

- Trim cable per trim code below; tin end of center conductor.
- Slide heat-shrink tubing and crimp sleeve over cable.
- Flare cable braid by rotating dielectric and slide cable into crimp tail.

2

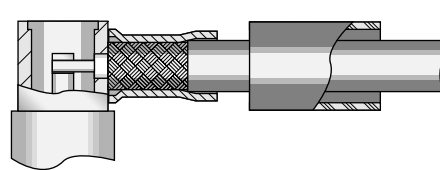

- Position cable so braid touches rear of body assembly.
- Slide crimp sleeve forward to touch rear of body assembly.
- Crimp braid with appropriate die size from chart below.

3

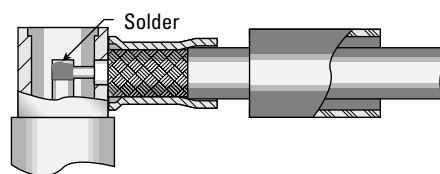

- Solder center conductor into notch in rear of contact with .025–.032" diameter chisel-tip soldering iron.
- Solder should cover center conductor, but not extend over top of notch in contact, or exceed contact diameter.

4

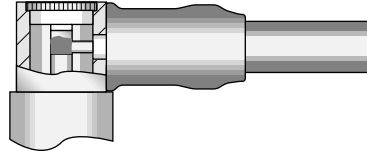

- Place insulator in body cavity, and press cap into place. Properly assembled cap will be slightly below end of body assembly.
- Slide shrink tubing over crimp sleeve and shrink to fit.

Crimp Die Sizes

CABLE GROUP	HEX DIE SIZE
02	.105
03	.128
05	.128
19	.128

Cable Assembly Instructions

Solder-clamp connectors for semi-rigid cable

Straight Connectors—Semi-Rigid Cable

Parts list

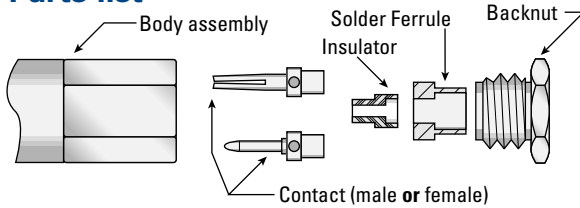

1

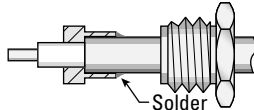

- Trim cable per trim code below; tin end of center conductor.
- Slide backnut over cable. Slide solder ferrule over cable until it stops against cable jacket.
- Solder cable jacket to ferrule.

2

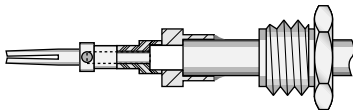

- Assemble insulator and contact onto cable dielectric and center conductor. If insulator is not flush against solder ferrule due to dielectric extrusion, retrim dielectric.
- Solder contact to center conductor by heating rear of contact (do not feed additional solder through inspection hole in contact).

3

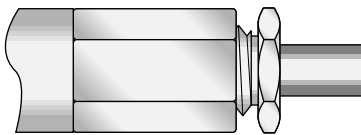

- Insert cable assembly into body assembly. Tighten to 90–100 inch-ounces torque. (Hold cable/hardware assembly stationary and rotate body when tightening.)

Right Angle Connectors—Semi-Rigid Cable

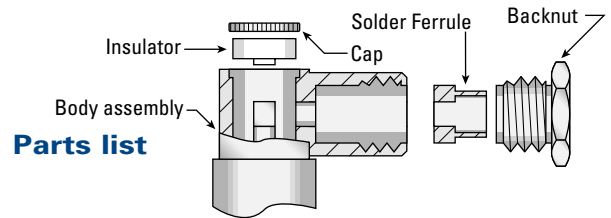

Parts list

1

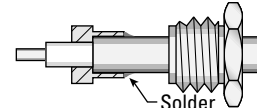

- Trim cable per trim code below; tin end of center conductor.
- Slide backnut over cable. Slide solder ferrule over cable until it stops against cable jacket.
- Solder cable jacket to ferrule.

2

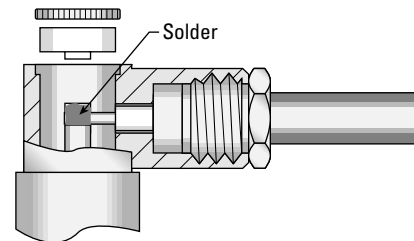

- Insert cable assembly into body assembly. Tighten to 90–100 inch-ounces torque. (Hold cable/hardware assembly stationary and rotate body when tightening.)
- Solder center conductor into notch in rear of contact with .025–.032" diameter chisel-tip soldering iron.
- Solder should cover center conductor, but not extend over top of notch in contact, or exceed contact diameter.

3

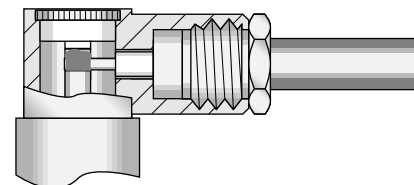

- Place insulator in body cavity, and press cap into place. Properly assembled cap will be slightly below end of body assembly.

Cable Trim Dimensions

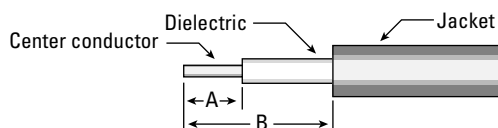

CONNECTOR TYPE	A	B
STRAIGHT CONNECTORS— .085" cable	.090	.170
STRAIGHT CONNECTORS— .141" cable	.105	.130
RIGHT ANGLE CONNECTORS	.110	.150



Mounting Dimensions

Bulkhead Receptacles

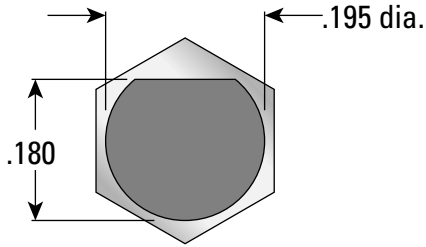

Flat of mounting surface is aligned with body hex as shown.

P.C. Board Receptacles

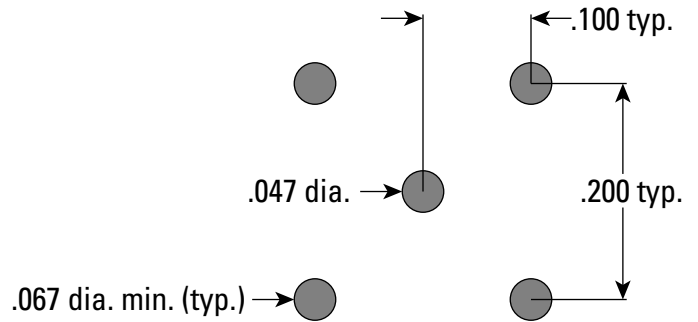

Assembly Tooling

Crimp tool

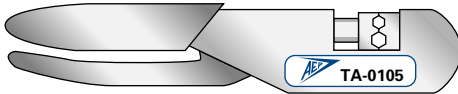

DESCRIPTION	AEP P/N
Crimp tool with .105" and .128" hex dies	TA-0105

Torque Wrench



DESCRIPTION	AEP P/N
Torque wrench with 7/32" jaws for SMC connector backnuts; 95 inch-ounces torque	TA-0436
Torque wrench with 7/32" jaws for SMC coupling nuts; 3 inch-pounds torque	TA-0398

Capping Press

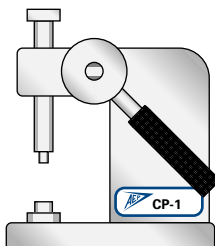

DESCRIPTION	AEP P/N
Capping tool (arbor press) with base for SMC right angle plugs	CP-7
Capping tool (arbor press) with base for SMC right angle jacks	CP-8

Index by Part Number

Click on any line below to go directly to the appropriate page

P/N	Page	P/N	Page
1001-1541-0XX*	5	1037-7511-051	14
1001-1551-0XX*	5	1041-1541-0XX*	5
1001-1571-0XX*	5	1041-1551-0XX*	5
1001-7541-0XX*	5	1041-7541-0XX*	5
1001-7551-0XX*	5	1041-7551-0XX*	5
1001-7571-0XX*	5	1042-1511-000	9
1002-1541-0XX*	4	1042-7511-000	9
1002-1551-0XX*	4	1092-1511-001	11
1002-1571-0XX*	4	1092-1511-002	11
1002-7541-0XX*	4	1092-1511-003	11
1002-7551-0XX*	4	1092-7511-001	11
1002-7571-0XX*	4	1092-7511-002	11
1003-1541-0XX*	6	1092-7511-003	11
1003-1551-0XX*	6	1105-1521-0XX*	4
1003-1571-0XX*	6	1105-7521-0XX*	4
1003-7541-0XX*	6	1106-1521-0XX*	6
1003-7551-0XX*	6	1106-7521-0XX*	6
1003-7571-0XX*	6	1109-1511-000	8
1004-1511-000	7	1109-7511-000	8
1004-7511-000	7	1110-1511-000	9
1005-1541-0XX*	4	1110-7511-000	9
1005-1551-0XX*	4	1141-1521-0XX*	5
1005-7541-0XX*	4	1141-7521-0XX*	5
1005-7551-0XX*	4	1484-1511-000	10
1006-1541-0XX*	6	1484-7511-000	10
1006-1551-0XX*	6	1486-1511-000	10
1006-7541-0XX*	6	1486-7511-000	10
1006-7551-0XX*	6	1488-1511-000	10
1009-1511-000	8	1488-7511-000	10
1009-7511-000	8	1490-1511-000	10
1010-1511-000	9	1490-7511-000	10
1010-1511-001	9	5807-1501-000	13
1010-7511-000	9	5807-7501-000	13
1010-7511-001	9	5808-1501-000	13
1012-1511-000	7	5808-7501-000	13
1012-7511-000	7	5813-1501-000	12
1017-1511-000	9	5813-7501-000	12
1017-7511-000	9	5815-1501-000	13
1019-1511-000	7	5815-7501-000	13
1019-7511-000	7	5816-1501-000	12
1025-1511-000	8	5816-7501-000	12
1025-7511-000	8	5822-1501-000	12
1029-1211-001	11	5822-7501-000	12
1029-1211-002	11	CP-7	18
1029-1211-003	11	CP-8	18
1029-7211-001	11	TA-0105	18
1029-7211-002	11	TA-0398	18
1029-7211-003	11	TA-0436	18
1036-1511-051	14		
1036-7511-051	14		
1037-1511-051	14		

* Indicates cable connectors with various types on specified page.



About Applied Engineering Products

Since our foundation in 1973, we have always believed that having our customers take a look "inside AEP" is important in fostering strong vendor/customer relationships. We are proud of our physical plant and equipment, but even more so of our dedicated staff. When customers see first-hand how AEP's people keep a constant focus on maintaining and improving

customer service and satisfaction, the reason for our consistently strong on-time delivery and quality records becomes clear.

We invite you to see for yourself. Call us to arrange a plant tour—or, if you can't make a visit, ask for your copy of *INSIDE AEP*, our facilities and capabilities brochure.



APPLIED ENGINEERING PRODUCTS

(203) 776-2813 • FAX (203) 776-8294

www.aepconnectors.com • aepsales@aepconnectors.com

The SMC connectors in this brochure are only part of our complete line of subminiature coaxial connectors and cable assemblies, including:

- SMA
- SMB
- SMC
- SSMB
- SSMC
- SLB (Slide-on version of SMB)
- SSLB (Slide-on version of SSMB)
- 75Ω Snap-on mating
- 75Ω Screw-on mating
- Adapters within and between series
- Flexible cable assemblies
- Semi-rigid cable assemblies
- And over 100 styles of MIL-PRF-39012 QPL connectors in series SMA, SMB, and SMC

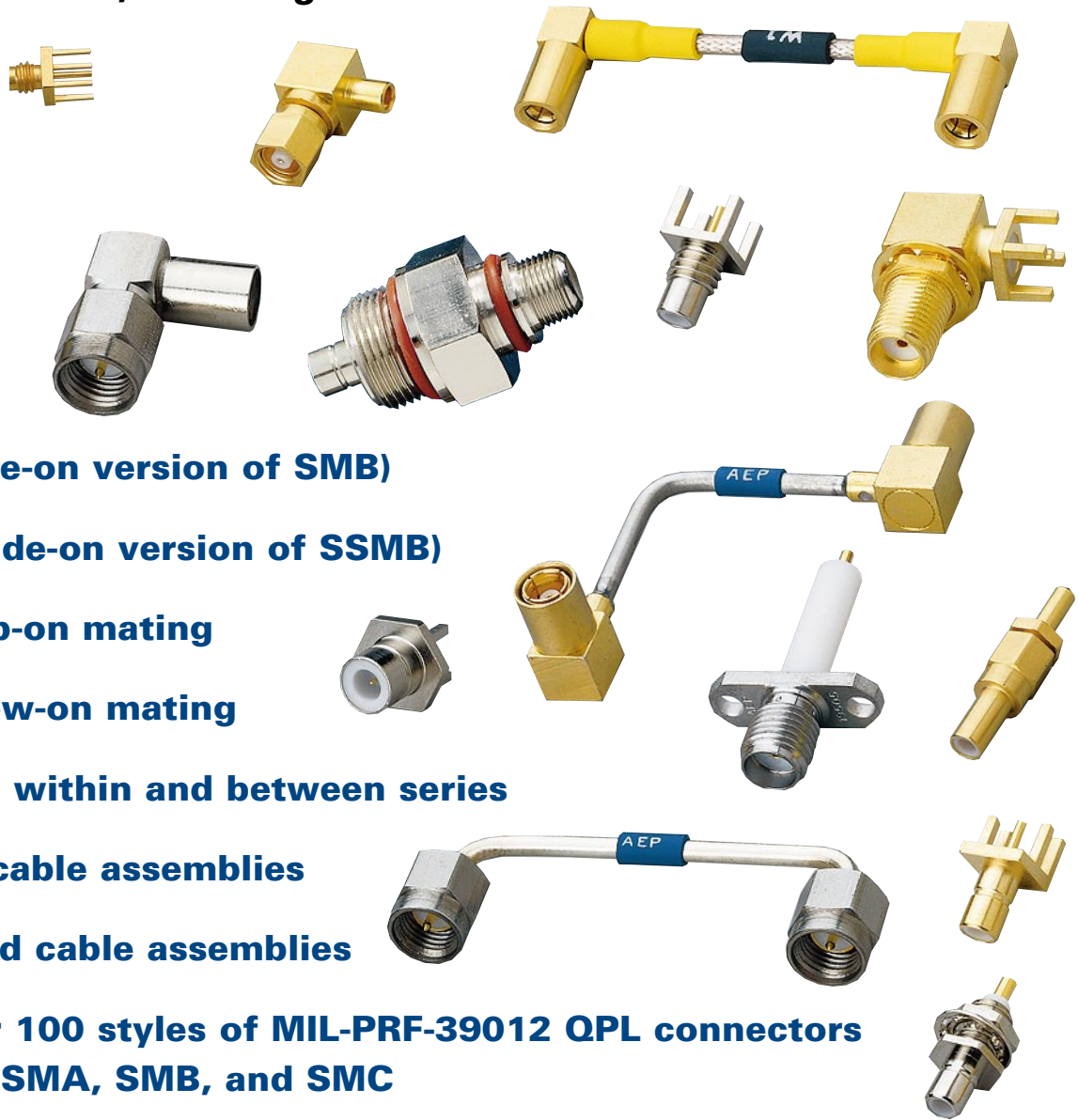

Call for your copy of our 184-page full catalog to see them all.



ISO 9001
CERTIFIED



APPLIED ENGINEERING PRODUCTS

104 John W. Murphy Drive • P.O. Box 510 • New Haven, CT 06513

(203) 776-2813 • FAX (203) 776-8294

www.aepconnectors.com • e-mail: aepsales@aepconnectors.com